

## Wide view mast VM

Mast Model	Load center 500mm		Max. lift height	Mast height		Tilt angle	Weight		
	FD 20T	FD 25T		Fork lowered	Fork lift with backres		Fwd-bwd	FD 20T	FD 25T
	Kg	Kg		mm	mm		deg	mm	kg
VM250	2000	2500	2500	1770	3555	6-12	3200	3540	
VM270	2000	2500	2700	1870	3755	6-12	3215	3555	
VM300	2000	2500	3000	2020	4055	6-12	3240	3580	
VM330	2000	2500	3300	2170	4355	6-12	3265	3605	
VM350	2000	2500	3500	2270	4555	6-12	3280	3620	
VM375	2000	2500	3750	2395	4805	6-6 *6-12	3295	3635	
VM400	2000	2500	4000	2570	5055	6-6 *6-12	3340	3680	
VM425	1950 *2000	2450 *2500	4250	2695	5305	6-6 *6-12	3360	3700	
VM450	1900 *1950	2150 *2450	4500	2820	5555	6-6 *6-12	3380	3720	
VM475	1800 *1850	1850 *2350	4750	2945	5805	6-6 *6-12	3400	3740	
VM500	1650 *1700	1700 *2250	5000	3070	6055	6-6 *6-12	3420	3760	
VM550	*1500	*1700	5500	3370	6555	*3-6	3615	3955	
VM600	*1300	*1400	6000	3620	7055	*3-6	3655	3995	

## 2 Stage free lift mast VFM

Mast Model	Load center 500mm		Max. lift height	Mast height		Free lift with backrest	Tilt angle	Weight		
	FD 20T	FD 25T		Fork lowered	Fork lift with backres			fwd-bwd	FD20T	FD 25T
	kg	kg		mm	mm			mm	Kg	Kg
VFM250	2000	2500	2500	1770	3555	745	6-12	3260	3600	
VFM270	2000	2500	2700	1870	3755	845	6-12	3275	3615	
VFM300	2000	2500	3000	2020	4055	995	6-12	3305	3645	
VFM330	2000	2500	3300	2170	4355	1145	6-12	3330	3670	
VFM350	2000	2500	3500	2270	4555	1245	6-12	3345	3685	

## 3 Stage free lift mast VFMS

Mast Model	Load center 500mm		Max. lift height	Mast height		Free lift with backrest	Tilt angle	Weight		
	FD 20T	FD 25T		Fork lowered	Fork lift with backres			fwd-bwd	FD 20T	FD 25T
	Kg	Kg		mm	mm			mm	kg	kg
VFMS360	2000	2500	3600	1745	4630	745	6-6 6-6	3410	3750	
VFMS400	2000	2500	4000	1870	5030	870	6-6 *6-6	3445	3785	
VFMS435	1900 *2000	2200 *2400	4350	1995	5380	995	6-6	3475	3815	
VFMS450	1800 *1950	2050 *2350	4500	2045	5530	1045	6-6 *6-10	3485	3825	
VFMS470	1700 *1900	1900 *2300	4700	2110	5730	1110	6-6 *6-10	3500	3840	
VFMS500	1500 *1800	1600 *2250	5000	2245	6030	1245	6-6 *6-6	3535	3875	
VFMS540	1200 *1750	1300 *2150	5400	2370	6430	1370	3-6 *3-6	3565	3905	
VFMS600	900 *1650	950 *1800	6000	2595	7030	1595	3-6 *3-6	3655	3995	
VFMS650	*1500	*1550	6500	2810	7530	1810	*3-3	3835	4175	
VFMS700	*1250	*1250	7000	3030	8030	2030	*3-3	3885	4225	

### Notes:

(1)Max Lift height(without backrest):-580mm (2)Free lift height(without backrest):+580mm;Weight without backrest:-30kg (3)Diesel forklift weight:+80kg

### Notes:

The mark of \* is with double tires,the weight withh double tries:+150kg  
Lift speed with VFM/VFMS VFM:FG 400mm/s full load,450mm/s no load;FD 400mm/s full load,420mm/s no load  
VFMS:FG 410mm/s full load,470mm/s no load;FD 420mm/s full load,440mm/s no load  
Lowering speed:VFM/VFMS 400mm/s full load,300mm/s no load.



\*products and its specifications change without prior notice

Distributor:

Version 2.0/2023/01

# TFT

# FD Series 20-25 Counter Balanced Forklift



## Three Features



### 1 Cleaner, more efficient Engines

New engines, compliant with worldwide emission regulations.

### 2 Easy Maintenance

Detachable side covers for convenient inspection and simple maintenance. Integral layout of electrical parts and other system devices.



### 3 Easier entry and exit from an extra-wide step

The secure step with enlarged foot space enables greater comfort and less fatigue while entering and exiting the vehicle.



## Main Truck Specifications

		<b>TFT</b>					
Specifications	1	Manufacturer		TFT			
	2	Model		FD20T	FD25T		
	3	Load capacity		2000	2500		
	4	Load center		500			
	5	Power unit		Diesel			
	6	Operator type		Driver / seat			
	7	Tire type	Front / rear		Pneumatic		
	8	Wheels	Front / rear		2/2		
Dimensions	9	Max.lifting height		3000			
	10	Free lift		160			
	11	Fork size	L×W×T	1070X122X40			
	12	Tilt angle	Forward/backward	6/12			
	13	Overall length(without fork)		2460	2530		
	14	Total width		1150			
	15	Mast height(fork lowering)		1995			
	16	Overall height fork raised		4030			
	17	Height of head guard		2120			
	18	Turning raduis(outside)		2170	2240		
	19	Load distance		466	466		
	20	Right angle stacking aisle(not add load length & clearance)		2615	2690		
Performance	21	Travelling	Full load	km/h	18		
			No load	km/h	19		
		Lifting	Full load	mm/s	550		
			No load	mm/s	580		
		Lowering	Full load	mm/s	450		
			No load	mm/s	550		
22	Speed	Power shift T/M	Full/no load	kg	1670/830		
23	Gradeability at 1.6km/h	Power shift T/M	Full/no load	%	27/20		
Weights	24	Max.drawbar pull	Power shift T/M	Full/no load	kg	1670/830	
	25	Gradeability at 1.6km/h	Power shift T/M	Full/no load	%	23/18	
	26	Truck Weight		kg	3330	3670	
	27	Weight distribution	Full load	Front	kg	4700	5410
Rear				kg	630	760	
No load			Front	kg	1510	1430	
			Rear	kg	1820	2240	
Chassis & Wheels	28	Number	Front/Rear	2 / 2			
	29	Tires	Model	Front	7.00-12-12PR		
			Rear	6.00-9-10PR			
	30	Wheelbase	mm	1600			
	31	Tread	Front	mm	970		
			Rear	mm	970		
32	Ground clearance	At lowest point(mast)	mm	110			
		Frame	mm	115			
33	Brake	Service brake	Hydraulic-foot pedal				
		Paking brake	Mechanical-hand lever				
Drive Line	34	Battery	Voltage / capacity	V/AH	12/80		
	35	Engine	Model	ISUZU C240	xinchai 498		
			Rated power	KW/rpm	35.4/2500	36.8/2400	
			Rated torque	N.m/rpm	139.9/1800	186/1600-1800	
			Number of cylinders		4	4	
			Displacement	L	2.36	3.2	
36	Fuel tank capacity	L	55				
37	Transmission	Shift stage (front / rear-type)	Power shift T/M	1-1 power shift T/M			
38	Operating pressure	Hydraulic system pressure	kg/cm2	180			

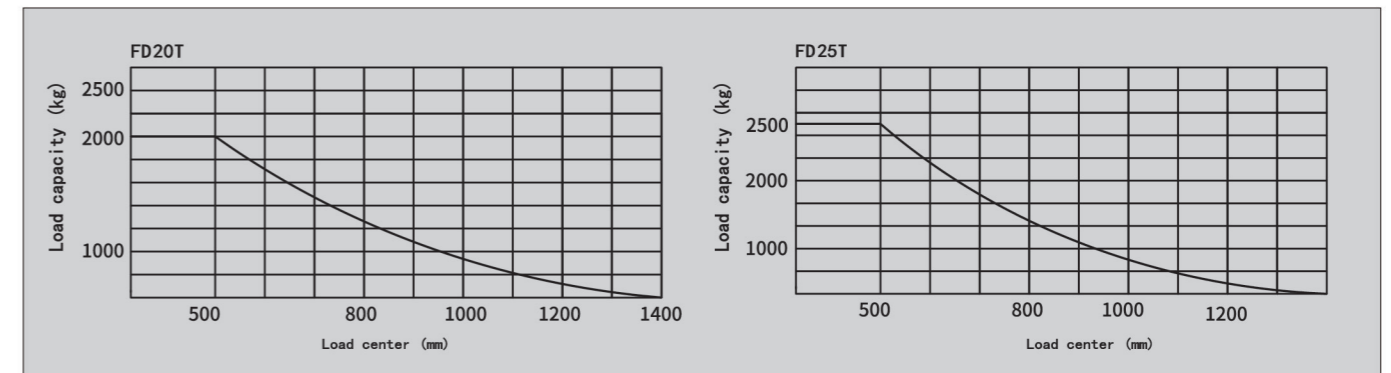

Notes:

Vertical axis represents load capacity; Horizontal axis shows load center, Load center is determined from front face of the fork.  
Capacity based on a 1000mm cube load configuration with the center of gravity at the true center of the cube, and standard fork.  
The load capacity will be reduced while the mast tilt forward or loading with long fork or lifting transformable width of goods.  
Getting the load capacities at the various load centers timely via the load curve.  
TEU's products and specifications change without prior notice.  
TEU forklift truck has equipped with standard safety device.  
TEU is not responsible for the damage occurred by removing its safety device.

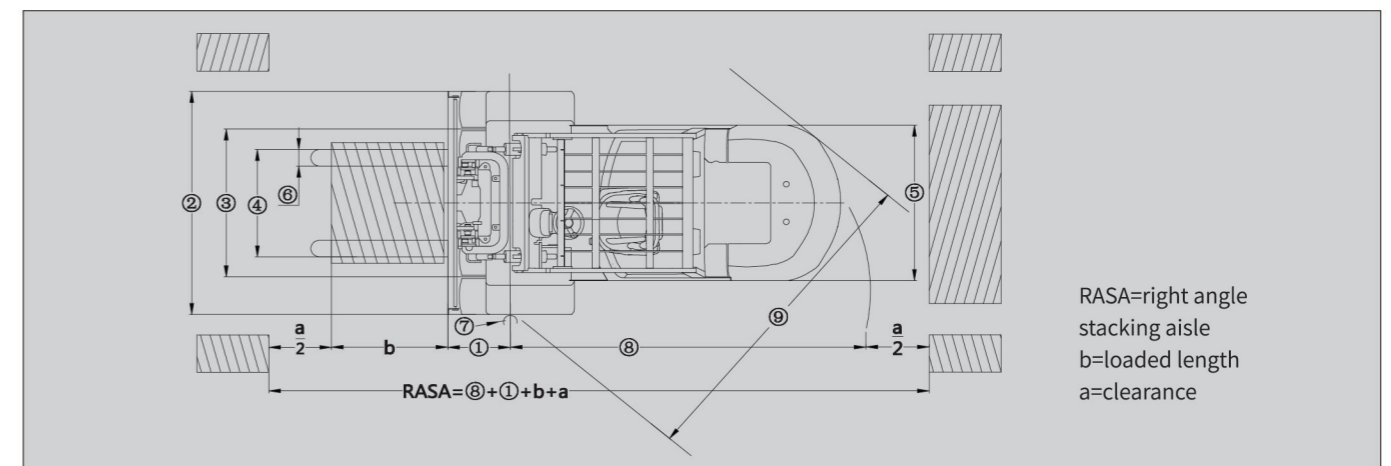

Specifications(front single tires).

Model	FD20T (mm)	FD25T (mm)
①Front Overhang	395	466
②Total Width	1070	1150
③Front Track	890	970
④Fork Spread(outside)	200~920	245~1020
⑤Rear Track	900	970
⑥Fork Width	100	122
⑦Turning Radius(inside)	110	160
⑧Turning Radius(outside)	2040	2240
⑨Right Angle Turning Aisle	1840	2010

**Standard equipments:**

Wide view mast, Cyclone air cleaner, Load one-way valve, Preheat indicator, King Pin, Engine-start switch, Standard backrest, Long-life tires, Overhead guard, Oil and water separator, Power steering, Adjustable steering column, Radiator water tank, Side roller, Standard carriage, Oil temperature cooler, Headlamp and steering indicator lamp, Charge indicator lamp, Hour meter, Oil warning light of engine, Water temperature gauge, Fuel gauge, Reversing light, Electric horn, Neutral-safety switch, Paper file, Rear mirror, Tools, Reversing Buzzer, General seat.

**Options:**

Fire extinguisher, cab, Heater unit, Rear work light, Solid tires, Fireproof silencer, Upper exhaust pipe, Tilt cylinder jacket, Rotating warning light, LPG Conversion device, Pre-filtration air intake device.

**Attachments:**

Side shifter, Fork positioner, Carpet boom, Fork extension, Long fork, Flat clamp, Others.